

RANGE

COLD APPLIED LIQUID PU SYSTEM

POLYURETHANE



FASTCOAT BUILD-UP



FastCoat is LRS' single component liquid applied polyurethane system, which provides fully bonded, tough, and durable seamless waterproofing. By using our exclusive polyurethane technology, we deliver systems that ensure long performance life and exceptional flexibility.

Polyurethanes are known for their exceptional strength and elastic properties. FastCoat offers complete systems for waterproofing roofs, balconies, gutters, and walkways.

Unlike many alternatives, FastCoat's fast cure technology offers substantial reductions in application time, saving money and reducing site disruption. Typically showerproof in 30 minutes and fully dried in approximately 4 hours. Smaller projects can often be completed in a day.

Its fully reinforced specification makes FastCoat suitable for flat, pitched, and vertical applications. Our standard FastCoat system comes with a 10 year guarantee.



FastCoat Pro is LRS' premier roof waterproofing system which offers an extended guarantee of up to 25 years. A fully reinforced, single component polyurethane system, FastCoat Pro offers an exceptional long-term solution to flat roof waterproofing, balconies, and walkways.

Because of their exceptional strength and elastic properties, polyurethanes are a popular choice for flat roofing contractors. FastCoat Pro is BRoof (t4) and BBA certified and fully accepted by NHBC.

Only available to LRS' Approved Installers, via the completion of our one day training course.

With the simple addition of FastCoat Traffic Coat, our FastCoat waterproofing system becomes a fully reinforced, anti-skid waterproofing system for application onto balconies, walkways, terraces, and car parks.

Suitable for application onto: OSB3 roofing boards, mineral felt, asphalt, concrete, metal, fibre glass, and compatible with standard GRP trims.



TYPICAL 10 YEAR BUILD UP

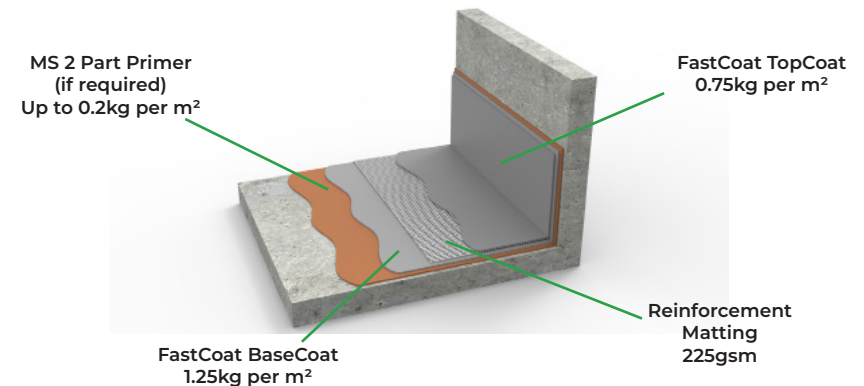

TYPICAL 20 YEAR BUILD UP

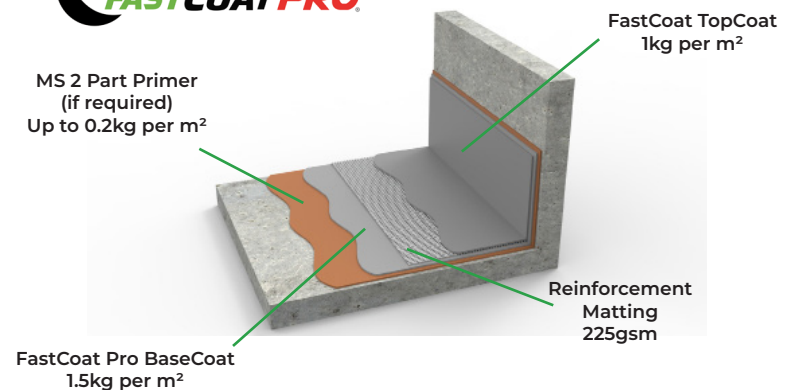

FASTCOAT BUILD-UP



TYPICAL 25 YEAR BUILD UP

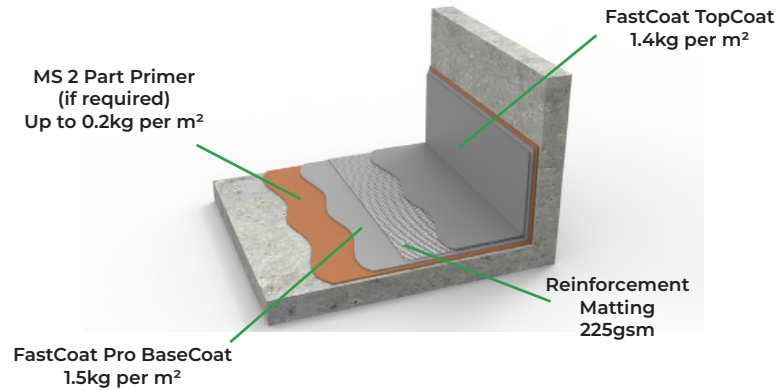

TRAFFIC COAT

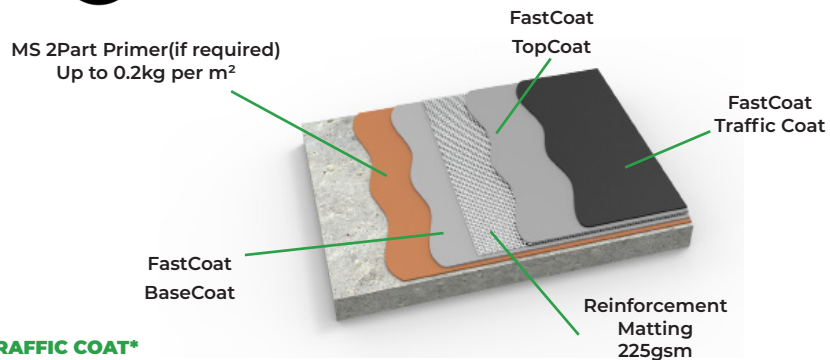

TRAFFIC COAT*

- Traffic Coat @ 0.2kg per m², Whilst wet cast 3kg per m² of aggregate, Brush off loose aggregate, then additional 0.2kg per m² of Traffic Coat.

BENEFITS

- ✓ Fast Curing
- ✓ 30 mins showerproof
- ✓ Single Component
- ✓ Applied in 2 Coats
- ✓ Seamless
- ✓ Extremely Elastic

SUITABLE SURFACES

OSB3	No primer	No primer
Mineral Felt	No primer	No primer
Asphalt	No primer	No primer
Concrete	MS 2 Part Primer	MS 2 Part Primer
Metal	MS 2 Part Primer	MS 2 Part Primer
Fibre Glass/GRP	MS 2 Part Primer	MS 2 Part Primer
Single ply	MS 2 Part Primer	MS 2 Part Primer
*Foil faced carrier membrane	MS 2 Part Primer	MS 2 Part Primer

*Foil faced carrier membrane - Elotene DSN600

TECHNICAL STATISTICS

Dry film thickness	Minimum 2mm
Application rate	2kg - 2.9kg
Cure time	2 - 4 hours
Fire test	Broof(t4)
Application temperature	+5°C - 35°C (surface)
Specific gravity	1.3kg/cm ³
Load strength	14N/mm (150 34-1)
Elongation	600%

PRODUCT RANGE TABLE

PRODUCT	SIZE	CODE	COLOUR
FastCoat	4kg	FC4	Grey RAL 7046
FastCoat	25kg	FC25	Grey RAL 7046
MS 2 Part Primer	12.5kg	FCMS2PI2.5	Clear
Traffic Coat	5kg	FC	Clear
Emery Aggregate	25kg	FCEA25	Brown
PU Mastic	600ml	PUM600	Grey
PU Mastic Gun	-	PUMGUN	-
Reinforcement Matting 225gsm	1m x 130m	CSJT1130	White
Reinforcement Matting 225gsm	1m x 25m	CSJT125	White

TRAINING

BECOME AN LRS APPROVED INSTALLER

As a member of LRWA and accepted by the NFRC, we are passionate about waterproofing standards and ensuring contractors are fully trained on our systems so that projects are completed quickly and effectively.

Whilst our systems are designed to be comprehensive to apply and do not require application by an approved installer, in order to get the best performance and benefit from extended guarantees we offer approved installer status on all our systems.

APPROVED INSTALLER STATUS

LRS deliver approved installer training schemes on all our systems. We offer installers full support and entry onto a preferred contractor list. As an approved installer you will receive exclusive access to our Pro systems across all our ranges including RapidRoof Pro, RapidRoof Pro Gutter, RapidDeck Pro, FastCoat Pro and Elasto-Kote Pro. These are the third-party accredited systems which offer BBA, BDA, FM, and NHBC accepted applications for New Build.

1 DAY TRAINING COURSE

Our approved installer training is a comprehensive 1-day programme which is highly recommended for both experienced liquid applicators and contractors new to liquid applied systems, as it provides valuable time saving tips and essential techniques.

TECHNICAL

At the heart of everything that LRS does is our dedication to product performance and technical excellence. We believe that liquid waterproofing provides the best solution for commercial and residential roofs, gutters, and car parks.

We are dedicated to continually improving the quality of our products and services. Our technical team, supported by field based technical managers provide site specific specifications, telephone, and onsite support.

Our downloadable product data sheets, application guides, and certifications can be found on our website www.lrs-systems.co.uk.

For further information about specific technical data or site specific specifications contact our technical team who will be happy to assist on **01948 841 877** or email technical@lrs-systems.co.uk.



**BECOME AN
APPROVED
INSTALLER**

**UP TO
25 YEAR
GUARANTEES**



GUARANTEES AND TESTING

Our systems are tested to the highest standards to ensure they are fit for purpose and deliver exceptional performance.

We only manufacture and distribute high performance materials and as such all our systems come with a 10 year guarantee as standard, with our pro ranges offering extended guarantees of up to 25 years.

Our products are third party accredited by the largest testing houses in Europe and the United States including BBA, BDA and Factory Mutual. Our production processes are externally audited to ensure complete quality control.

We continually test our products to the latest standards and whilst our testing certificates are available on our website our technical team are on hand to deal with specific test enquiries.

For further information visit www.lrs-systems.co.uk or call our team on **01948 841 877**.

PRODUCT GUARANTEES

RapidRoof	10 Year
RapidRoof Pro	Up to 20 Year
RapidRoof Gutter	10 Year
RapidRoof Pro Gutter	Up to 20 Year
RapidRoof Balcony	10 Year
RapidDeck Car Park	10 Year
FastCoat	10 Year
FastCoat Pro	Up to 25 Year
Elasto-Kote	10 Year
Elasto-Kote Pro	Up To 20 Year



LIQUID ROOFING SYSTEMS

 Roofing House, Prees Green, Whitchurch, SY13 2BN

 01948 841 877

 enquiries@lrs-systems.co.uk

 www.lrs-systems.co.uk

Visit our website

